

Sun City Lincoln Hill ARC Application Checklist

Trash Enclosures

Checklist 28

Owners of open space or golf course properties may construct a special enclosure to store trash and yard waste containers out-of-sight of neighboring properties. Owners may choose to construct a joint or single property enclosure using any of the approved options shown on page 2 of this checklist.

This Checklist is for GUIDANCE ONLY, please refer to the CC&Rs and the Design Guidelines for all other specific requirements relating to your project.

OWNER CHECKBOXES (Must be filled in or noted N/A)

ARC CHECKBOXES

Brief Project Description _____

Required Documents

• Drawing showing the location, and the size of the trash enclosure.

The enclosure will be constructed, as shown on page 2 of this checklist, using 1, (one), of the options, (checked below).

Option 1: Wood panels with wood lattice.

Option 2: All wood or vinyl panels.

Option 3: All stucco.

Option 4: All lattice.

The enclosure will be a single enclosure as shown in (Figure 27.1) with a minimum setback of one inch (1") from the property line.

The enclosure will be a shared enclosure as shown in (figure 27.2) and will be constructed on the property line. The owner of the adjoining property signed the "Shared Trash Enclosure Agreement"

The enclosure will be constructed on a solid, level surface.

The Enclosure will be painted the same as the home's main body color or be an approved vinyl panel color. Shared Enclosures will be painted the Applicant's home body color.

Owner understands the enclosure location, but not dimensions, may be field adjusted a maximum of two feet (2'-0") without re-application. Any greater adjustment requires ARC approval.

The timeline for completion of work is within 90 calendar days from the start of work and must be completed before the one-year approved application period expires.

This checklist must be completed and signed by the Owner along with the Architectural Review Committee, (ARC) Application Form

Homeowner Use

Planned Completion Date:

Name:

Address:

Signature:

ARC Use Only

APPROVED _____

INCOMPLETE _____

DISAPPROVED _____

Date: _____

Fig. 26.1 Single Enclosure Plan View

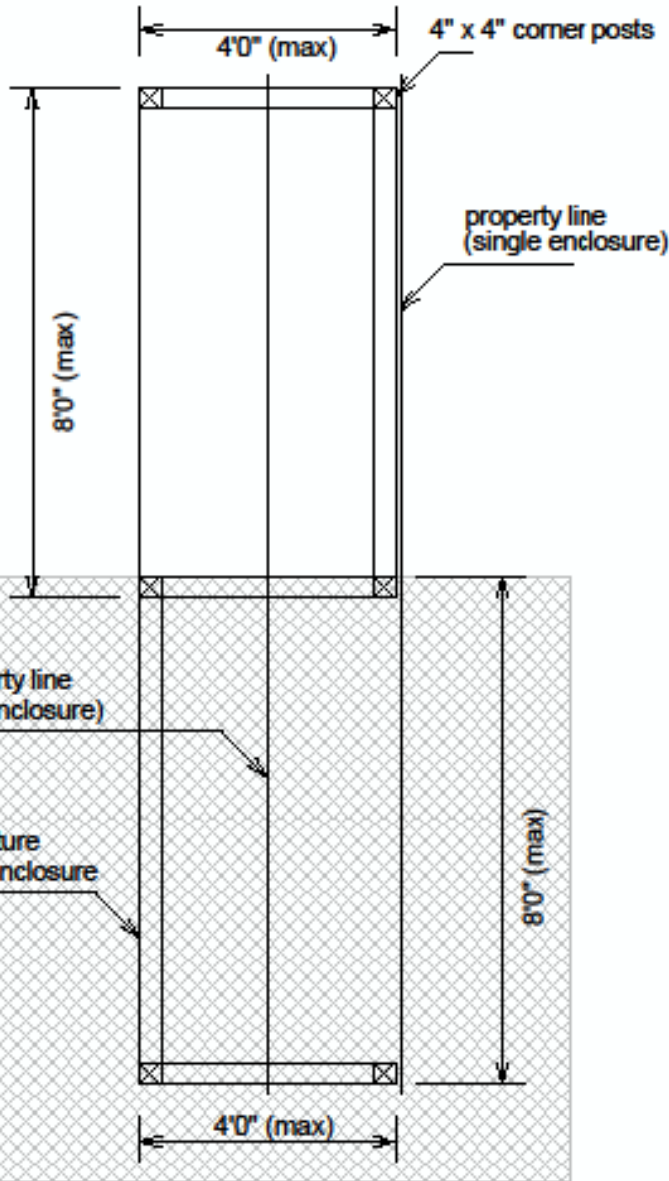

Option 1 - Panels with Slated lower section & Lattice upper section

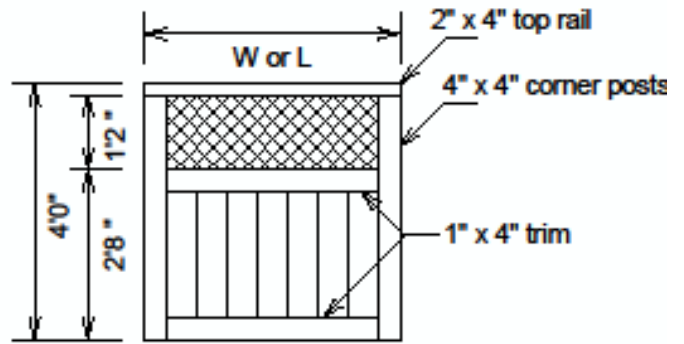

Option 2 - Panels with slats

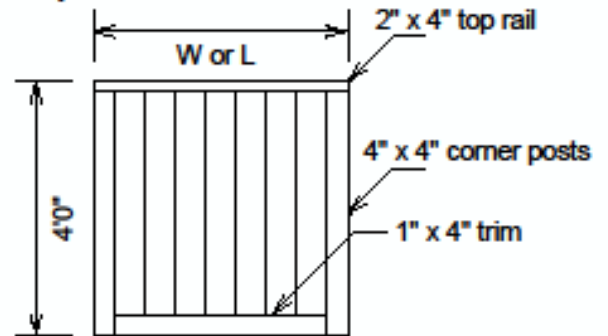

Option 4 - Panels with all Lattice

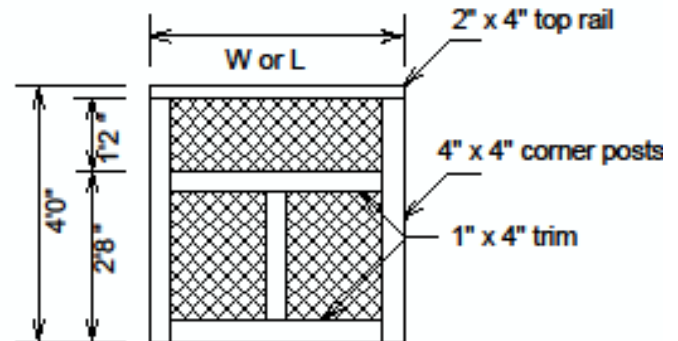
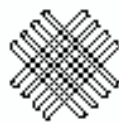

Fig. 26.2 Shared Enclosure Plan View

(For Shared Enclosure add the structure in the shaded area and center on the property line)



**Recommended Lattice Configuration
1 5/8" wide lattice with 2" openings**



Trash Enclosure Dimensions

Enclosure Side Length (L) - 8'0" (max)
Enclosure End Width (W) - 4'0" (max)

**Recommended "Good Neighbor"
Slat Configurations**

-  in line
-  staggered

Sun City Lincoln Hill ARC Application Checklist

Shared Trash Enclosure Agreement

Owners of open space or golf course properties may construct a special enclosure to store trash and yard waste containers out-of-sight of neighboring properties. Owners may choose to construct a joint or single property enclosure using any of the approved options shown on page 2 of this checklist. This joint "Shared Trash Enclosure Agreement" with the owner of the adjacent lot must be included for a joint enclosure.

1. I/we _____ Owners of Lot #: _____ Village # _____
Applicant Print Name above

Property Address: _____
and

2. I/we _____ Owners of Lot #: _____ Village # _____
Adjacent Lot Owner Print Name above

Property Address: _____

As Owner(s) of the above Lots we have applied for a joint trash enclosure to be located on the property line of the above described Lots as indicated on the Application Plot or Landscape Plan, which includes dimensions, material and color.

The ARC will consider approval of the joint trash enclosure at the location based on the following terms and conditions.

AGREEMENT

We agree that the joint trash enclosure will be constructed on the common Lot line and is a common fence and that in the event the party wall/common fence is destroyed or damaged, including deterioration from ordinary wear and tear, the responsibility for maintenance shall be as stated in Section 7.06 of the Association's CC&R's.

1. _____
Owners signature - Applicant *Lot #/Village #* *Date*

2. _____
Owners signature - Ajacent Lot *Lot #/Village #* *Date*